

(12) **UK Patent Application** (19) **GB** (11) **2 377 578** (13) **A**

(43) Date of A Publication 15.01.2003

(21) Application No **0211159.9**

(22) Date of Filing **15.05.2002**

(30) Priority Data

(31) **0111850** (32) **15.05.2001** (33) **GB**

(71) Applicant(s)

British Broadcasting Corporation
(Incorporated in the United Kingdom)
Broadcasting House, LONDON, W1A 1AA,
United Kingdom

(72) Inventor(s)

Andrew Kevin McParland
Timothy John Sargeant
Guy Quentin Winter
John Christopher William Newell
Hywel James Williams
Nigel C Earnshaw

(74) Agent and/or Address for Service

Mathys & Squire
100 Grays Inn Road, LONDON, WC1X 8AL,
United Kingdom

(51) INT CL⁷

H04N 5/455 7/088

(52) UK CL (Edition V)

H4F FBBG

(56) Documents Cited

GB 2325537 A **WO 2000/040021 A1**
WO 2000/016548 A1 **US 6005597 A**

(58) Field of Search

UK CL (Edition T) **H4F FBB FBBG**

INT CL⁷ **H04N 5/455 7/088**

Other: **Online: EPODOC, PAJ, WPI**

(54) Abstract Title

Creating a viewing schedule using broadcast and stored programmes

(57) A method and apparatus for creating a viewing schedule for a user. Broadcast programs from a number of sources, such as terrestrial television, the internet or DVDs can be compiled into a broadcast schedule which is 'tailored' to a user, or a group of users. By allowing programmes to be played live, pre-recorded, or time delayed, a virtual channel can be created based upon user preference information. The schedule may indicate the source, timing and other information such as the cost of a programme, and may allow a user to modify the proposed schedule, and the stored user preference information.

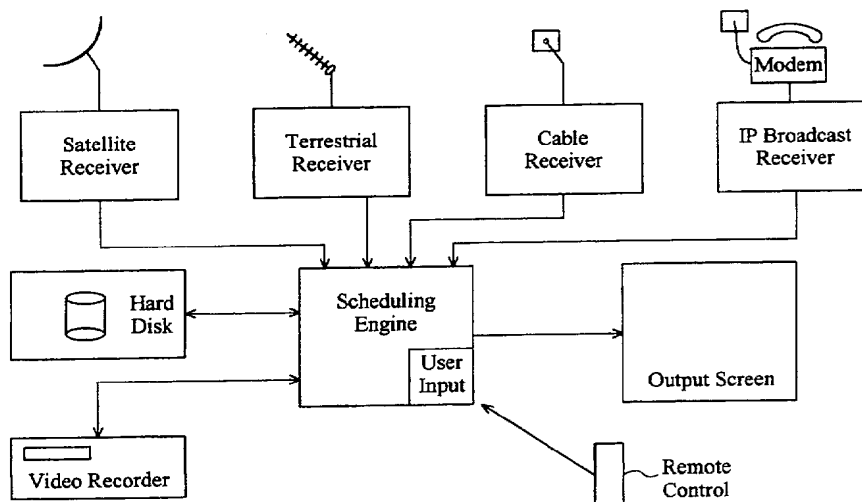

Fig. 2

At least one drawing originally filed was informal and the print reproduced here is taken from a later filed formal copy.

The specification as filed includes a computer program which is not reproduced here; it may be inspected in accordance with Section 118 of the Patents Act 1977.

GB 2 377 578 A

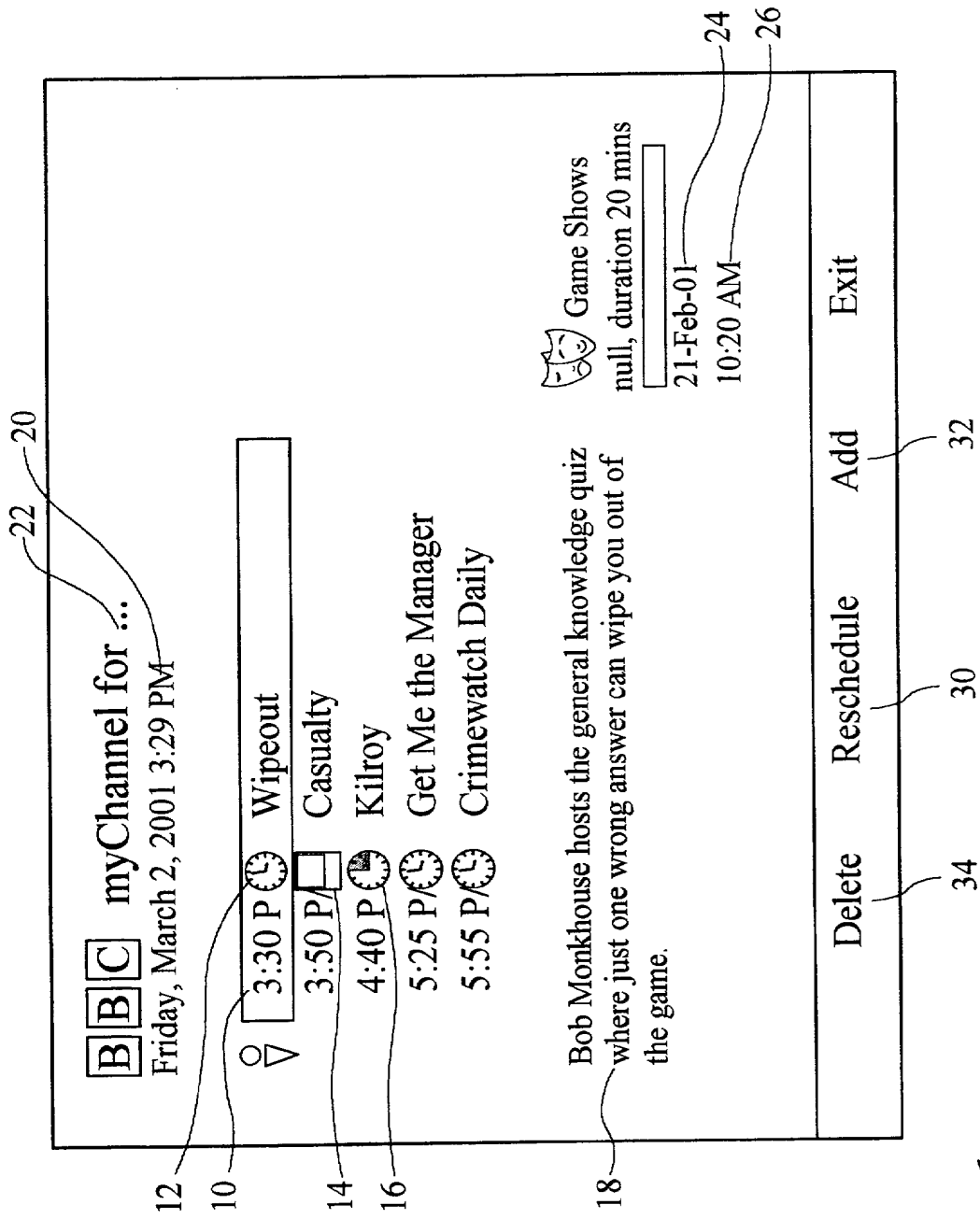

Fig. 1

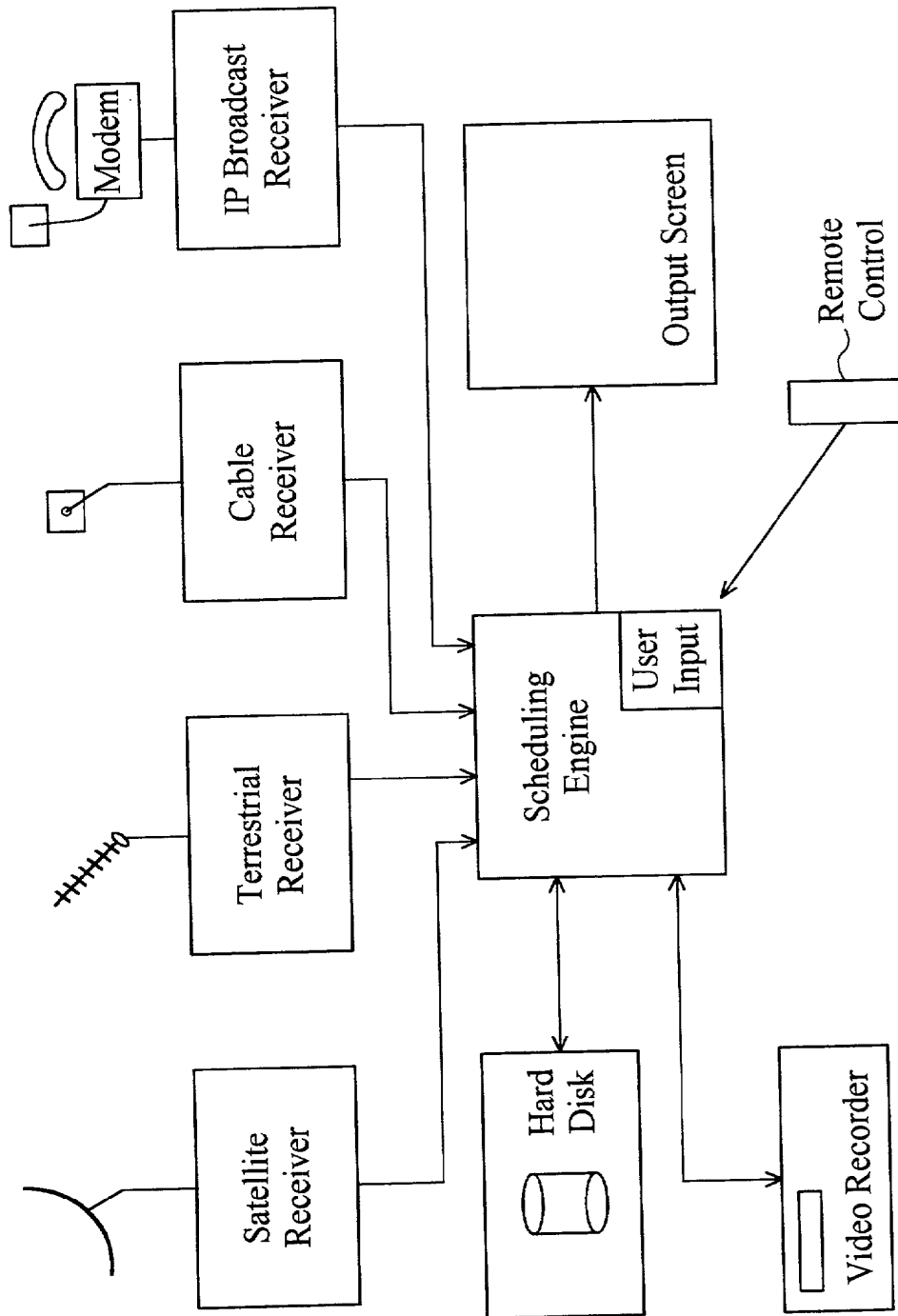

Fig. 2

Virtual Media Channel

The present invention relates to delivery of a schedule of media programmes to a user. The invention is particularly, but not exclusively, concerned with delivery of television programmes but may be applied to delivery of audio only (for example radio programmes) or multi-media presentations or other interactive entertainment and the term media programme as used herein is intended to encompass any form of audio and/or visual experience delivered to a user.

With the advent in recent years of cable, satellite and digital television, the number of channels available to a user has greatly increased. Whereas some users may be prepared to watch whatever is available or may be prepared to organise their personal schedules round the timing of television programmes, others may be more selective and/or may wish to view television only at certain limited times and may find that, despite the large number of channels available, there may be nothing of interest to them at the time they wish to view it.

Various methods and devices have been proposed to alleviate this problem. For many years, video recorders have been used to record programmes for later viewing at a more convenient time. More recently, digital storage devices have been produced which can continuously record many hours of programme transmission and enable time-shifting of programmes without advance programming. Such devices may also contain menus and may store user preferences in order to facilitate navigation through stored programmes or to select what is recorded.

US-A-5534911 discloses a device which evaluates a number of broadcast programmes and selects the "best" programme from the available for viewing and may also record the "best" programme of the day or week.

With tools such as the above and appropriate planning, a user can select from available programmes and decide what to watch.

However, the present invention stems from the realisation that, whilst such tools can be convenient for selecting a particular programme which the user wants to watch, in order to provide viewing for a given time period, a user may have to make numerous decisions and calculations and may end up compiling a sub-optimal collection of programmes to view in that period. Historically, efforts have been put into creating schedules of programmes for general viewing on a particular channel and all the benefits of the efforts of scheduling programmes are lost when tools such as the above are employed to time-shift programmes.

10 In a first aspect, the invention provides a method for creating a viewing schedule for a user comprising:

- receiving a schedule of broadcast programmes;
- receiving a list of stored programmes;
- storing user preference information;

15 compiling a schedule of programmes for the user selected from the schedule of broadcast programmes and the list of stored programmes, based on the user preferences.

Pursuant to the present invention it has been appreciated that conventional apparatus may assist in providing a greater variety of programmes from which to choose and tools for doing so but cannot effectively provide a coherent schedule of programmes for viewing which can include both "live" and stored programmes. Furthermore, the invention stems from the realisation that whilst certain programmes may readily be recorded and time-shifted, a user may derive greater benefit from viewing certain other programmes "live" that is at (or close to) the time at which they were intended to be viewed and conventional time-shifting devices, by their very nature which is intended to make, are not suited to this.

In contrast, with the invention, a personalised schedule can be created which integrates both stored programmes and broadcast (which term is intended to encompass any distribution format, including, but not limited to, digital or analogue

broadcasting, satellite or cable broadcasting and internet distribution) programmes and can take into account the time of broadcast of programmes.

5 The method may further comprise playing out media corresponding to the schedule.

In a closely related method aspect, the invention provides a method of providing a media channel which presents a sequence of programmes, the method comprising:

10 receiving media programmes from a plurality of sources including at least one source of recorded programmes and at least one source of broadcast programmes and presenting a sequence of programmes selected from the received programmes based on user preferences.

15 Preferably, the method includes selecting at least one programme from the schedule of broadcast programmes to play back at a time other than the time of broadcast of said programme. The method may include controlling a time-shifting recording device to play back the selected programme at the desired time. The time shifting device may be separate or integrated with the schedule generator.

20 Preferably, there is included on the schedule one or more status indicators for each programme. These status indicators may include timing indicators, cost indicators and source indicators for each programme. The method may include indicating on the schedule programmes which are live. Preferably, the method further includes indicating programmes which are pre-recorded. Preferably, the method further includes indicating programmes which are time-shifted. By time-shifted is meant recorded from a recent broadcast (recent may be defined by a user but will typically include programmes recorded the same day; however it may be up to 24 hours or 1 week) and which is temporarily stored and expected to be deleted from store after viewing (although the user may in some case be given an option to save a programme). Pre-recorded is intended to encompass media which is

“permanently” stored (that is it will not be over-written by the device unless specifically authorised) and may be from a media recording in the possession of the user.

5 Video on demand programmes may be treated as pre-recorded programmes. References to stored or pre-recorded programmes are intended to connote programmes which can be accessed on demand by a user; these may be locally stored (for example on a hard disk or video recorder) or may be available from a remote video on demand server. The term is intended to distinguish from broadcast
10 programmes (i.e. to exclude programmes whose playback time cannot be selected by the user).

 Video and audio programmes may be downloaded from a remote source, for example via the internet and may be stored for playback on demand, or for time
15 delayed playback. Programs may be downloaded at a rate different from that required for real-time playback and stored for real-time playback. The download rate may be less than the playback rate; this may reduce bandwidth requirements. Depending on the available bandwidth of a network connection or the pricing for the bandwidth, this may reduce cost or may enable a program to be downloaded while
20 another is watched. Scheduling may include setting a download time. For some media, eg. MP3, download may occur at a higher rate than playback.

 Other remote programme sources may include content available from, or via other entertainment systems distributed around the home which may be connected
25 using an in-home network.

 Preferably, the method includes presenting the schedule to the user and modifying the schedule in response to user input. This may allow a personalised schedule to be produced and then tailored to the user’s requirements; this may allow
30 the user flexibility but present the user with a reasonable schedule without requiring direct user input for a particular schedule. Modifying may include deleting programmes. This allows programmes to be permanently deleted from the

schedule. Modifying may include changing the order of programmes in the schedule. Modifying may include playing an available programme immediately in response to user selection and modifying the time of play of subsequent programmes.

5

Most preferably, information concerning user preferences is updated in response to user modification of a prepared schedule. In this way, the system can "learn" from the user's reaction to a given schedule.

10 The schedule may be prepared in advance of the start of the schedule. Alternatively, the schedule may be prepared starting immediately or imminently from the current time.

15 The schedule may be set to run for a predetermined period, for example an evening or a specified user time.

20 The schedule may include a planned break for the user to undertake other activity. A break may be scheduled at a convenient time, and if this coincides with a programme the user wishes to view, that programme can be recorded or time delayed for later viewing.

25 The schedule may include programmes which are not directly accessible by the scheduling device. For example cable, satellite or radio programmes or an internet live video broadcast may be included in the schedule, even if the user has to operate separate equipment to view the programmes. Thus the scheduler may be separated from the receiving equipment and may only receive a schedule but not the programme itself for certain media or programme sources. Similarly, the scheduler may include details of stored programmes (for example on video tape or DVD) and may insert these in the schedule, without necessarily being able to play
30 the programmes directly. Preferably, however, the scheduler is integrated with receiving apparatus for receiving at least one broadcast media channel and preferably also has means for time-shifting a received programme.

The method may include storing multiple user preferences and may include providing multiple user schedules. Alternatively the method may include providing a composite schedule in which programmes are selected according to different user preferences at different times. For example, a daytime schedule may be provided based on one user preference and an evening schedule may be provided based on another user preference and a yet further weekend schedule may be provided. Different user preferences may be merged; for example if two (or more) users who have individual preferences wish to view a schedule, programmes may be selected according to both (or all) users' preference information, in order to provide a selection suitable for both (or all) users.

In a greatly preferred implementation, the method comprises at least a step of ordering programmes according to time of broadcast or availability and a step of ordering the programmes according to closeness of match to user criteria. The ordering according to time is preferably performed as a first step. The ordering step is preferably performed so that pre-recorded programmes can be inserted at any convenient point, after the broadcast programmes have been ordered.

The method may be configured so that one or other source is favoured over another; this may be based on user preferences and/or time of day or week. Preferences may be expressed between broadcast channels and as between broadcast and pre-recorded programmes. For example, a hierarchy of preference may be specified as "BBC1, then other terrestrial, then pre-recorded, then satellite then cable" and this may be used to weight other parameters used in ranking programmes. Additionally or alternatively programmes may be selected according to type, in particular free to air programmes may be selected preferentially over pay-per-view broadcasts. The cost of a pay-per-view programme may also be taken into consideration when compiling a user schedule. This cost may be compared to a user's available pay-per-view credit or specified desired spending when scheduling takes place. The type of programme, whether free or pay-per-view may be indicated in the schedule. Additionally or alternatively the cost or a ranking or banding (e.g. free, less than x, more than x) of the cost of the programme may be displayed.

The invention extends to apparatus for performing any of the above methods.

The invention further extends to a computer program or computer program product arranged to perform any of the above method aspects.

5

The invention further extends to a schedule or sequence of commands to effect playback of a schedule produced by any of the above methods.

An embodiment of the invention will now be described by way of example, with reference to the accompanying drawings in which:-

10

Fig. 1 shows a screen shot of a schedule produced by the invention; and Fig. 2 is a schematic overview of the apparatus.

15 **Overview of the invention**

The embodiment provides a user with a personalised schedule of available programmes. This personalised schedule can be presented to the user as a listing of programmes in time order, similar to what would be on offer from a traditional broadcast channel. The schedule is arranged to contain the best content for that user. On initialisation, when no programmes are stored, this would be a choice of the live broadcasts. With the availability of storage (such as a hard disk in a set-top box or a video-on-demand server) the schedule can incorporate both live programmes as they are broadcast, time-shifted programmes to fit or tidy up the schedule, and those available on-demand (e.g. pre-recorded). An important feature is that the schedule can contain both live and recorded content as it is expected the user will still want to watch certain events live or near-live (e.g. a news or current affairs programme, or an episode of a series; such programmes can be identified and flagged as programmes to be included at or as close to the "normal" broadcast time as possible).

25
30

Advantageous features of the embodiment include:-

Personalised service

An agent or filtering tool chooses the most appropriate content for the selected user. This preference could be based on a combination of past choices by the user and related to the genre and type of content that the user watches. It may also be based on their preferences for watching particular types of programme at different times of day, e.g. a movie or drama between 8pm and 10pm. The aim of the personalization is to give the user a choice amongst the best that is on offer.

Virtual channel

The schedule would be virtual in the sense that it is not based on an existing broadcast schedule of programmes, but instead contains content from many different sources that was made available earlier. The schedule has been created in the box for the user. This means that it need not be stored or exist elsewhere, reducing distribution and storage resource requirements.

15

Adaptive

The schedule presented to the user can adapt to the time of day, in addition to personalization to the user's preferences. As time moves on the schedule will change.

20

Planned

There is an element of planning to the virtual schedule. The user can add or delete programmes from the proposed schedule. The user can also look ahead and plan their evening or weekend viewing. In addition, in contrast, the user can watch a schedule without prior planning of what to record or any effort in selecting programmes.

25

Content agnostic

The schedule does not just have to be conventional TV material (i.e. Audio/Video), it may be audio-only material. It may also be pointers to material that the box itself cannot acquire but has information on. For example, the box may have programme information for a radio station that it cannot tune to. The box notices that there is a concert by the user's favorite band and flags the event in the user's schedule. The delivery mechanism may be via traditional broadcast channels (e.g. via a teletext or Ceefax service) or via a broadband connection or phone-line or other internet connection. The mechanism for delivering a list of pre-recorded material may include storing details of what has been recorded under the control of the scheduler and may also include inputting, either from a user or from a separate device, details of pre-recorded material available to view.

Specific Implementation

Referring to Fig. 1, a screen shot from an embodiment is shown.

The schedule displayed shows the time of a programme 10, an icon indicating whether the programme is live 12, pre-recorded 14 or (marginally) time-shifted 16 and gives a summary 18 of the highlighted programme. The display also shows the date and time for which the schedule is prepared and has space to display the name of the user for whom it has been prepared. The display further shows the date on which the schedule has been prepared (the current date) 24 and time 26. The schedule includes inputs for rescheduling the currently highlighted event 30, adding an event 32 and deleting an event 34.

To summarize, the key advantages of this arrangement are:-

- Simple layout - uncluttered and direct.
- Informative - the "liveness" of a programme is indicated by icons, including straight from disk, time shifted and live.
- Personalized - the person or group that the screen is intended for is indicated directly.

The following sets out preferred criteria and constraints for implementing the scheduler.

Virtual Channel Behaviour

- 5 The virtual channel schedule is a short, ordered list of programmes that are time/availability ordered, then ordered in terms of a rating that reflects the quality of the match between the programme and the user preference information.

When the virtual channel is selected the programmes are played out sequentially.

10

The schedule will scroll upwards as each programme is replayed and the order of programmes will not change.

- 15 If the virtual channel is not selected then the order of the programmes may be revised as highly rated programmes become more immediately available and displace programmes earlier in the schedule.

20 The rating of programmes that remain in the schedule for some time but remain unwatched is progressively reduced so that ultimately they will be displaced by more recently broadcast content.

The first programme in the schedule preferably cannot be displaced once replay has been started.

25 User modifications

The user can preferably modify the schedule in one or more of the following ways:

- 30 - programmes may be removed. In this case they will preferably never reappear in the schedule.
- programmes may be moved about in the schedule, subject to time/availability constraints.

- programmes can be added to the schedule, subject to time/availability constraints.

5 - the user may choose to replay a programme further down the schedule. In this case it is immediately moved to the top of the schedule.

When a programme is added or removed from the schedule this is taken to indicate a user preference and can be used to refine the user profile information.

10 If a virtual channel with a modified schedule is continuously selected the order of programmes will not change and the behaviour is identical to the case when the schedule is unmodified.

15 However, if the schedule is not played out the dynamic behaviour is preferably different to an unmodified schedule in at least the following aspects:

- added programmes will not be displaced from the schedule until watched or removed by the user.

20 - the ordering of added programmes is preserved as they move forward in the schedule.

- the ordering of moved programmes is preserved but they may be displaced by higher rated programmes as they become available.

25

Schedule revisions

The virtual channel schedule may be revised in the following circumstances:

30 - the virtual channel is playing and the current programme finishes.
 - the user chooses to replay a programme that is later in the schedule.
 - the user removes, adds or moves a programme.
 - a new programme becomes available (a recording starts).

- the tuner (or other decoder or receiver) is not available when required so that the capture of a programme fails.

5 It will be apparent that numerous modifications to the above may be made and the above embodiment is illustrative only. By way of example only, Java code implementing an embodiment of the invention is appended hereto. Other than the right to make facsimile copies of the printed version of this patent application, all copyright in the code is reserved by the applicant.

Claims

1. A method for creating a viewing schedule for a user comprising:
receiving a schedule of broadcast programmes;
5 receiving a list of stored programmes;
storing user preference information;
compiling a schedule of programmes for the user selected from the schedule
of broadcast programmes and the list of stored programmes, based on the user
preferences.
10
2. A method according to Claim 1, wherein there is included on the schedule
one or more status indicators for each programme.
3. A method according to Claim 2, wherein said one or more status indicators
15 includes a timing indicator to indicate whether or not a programme is live
4. A method according to Claim 2 or 3 wherein said one or more status
indicators includes a timing indicator to indicate whether a non-live programme is
pre-recorded, or time-shifted.
20
5. A method according to any of Claims 2 to 4, wherein said one or more status
indicators includes a cost indicator.
6. A method according to Claim 5 wherein the cost indicator is arranged. to
25 display whether a programme is free, or pay-per-view.
7. A method according to any of Claims 2 to 6, wherein said one or more status
indicators includes a source indicator.
- 30 8. A method according to Claim 7 wherein the source indicator is arranged to
display whether a programme is derived from a broadcast or stored media and
preferably includes indicating at least one of terrestrial, cable, locally stored

programmes, video-on-demand, pre-recorded local media (for example DVD, video tape or other format), or internet derived.

5 9. A method according to any preceding claim further comprising playing out at least one item of media corresponding to the schedule.

10 10. A method of providing a media channel which presents a sequence of programmes, the method comprising:
receiving media programmes from a plurality of sources including at least one source of stored programmes and at least one source of broadcast programmes and presenting a sequence of programmes selected from the stored programmes and the broadcast programmes based on user preferences.

15 11. A method according to any preceding claim including selecting at least one programme from the schedule of broadcast programmes to play back at a time other than the time of broadcast of said programme.

20 12. A method according to Claim 11 including controlling a time-shifting recording device to play back the selected programme at a desired time.

13. A method according to Claim 12 wherein the time shifting device is separate from the schedule compiler.

25 14. A method according to any preceding claim including presenting the schedule to the user and modifying the schedule in response to user input.

15. A method according to Claim 14 wherein modifying includes deleting programmes.

30 16. A method according to Claim 14 or 15 wherein modifying includes changing the order of programmes in the schedule.

~~27~~

17. A method according to Claim 14, 15 or 16 wherein modifying includes playing an available programme immediately in response to user selection.
18. A method according to any preceding claim wherein information concerning user preferences is updated in response to user modification of a prepared schedule.
19. A method according to any preceding claim wherein the schedule is prepared in advance of the start of the schedule.
20. A method according to any preceding claim wherein the schedule is set to run for a predetermined period.
21. A method according to any preceding claim wherein the schedule includes a planned break for the user to undertake other activity.
22. A method according to Claim 21 including selecting a programme to record for later playback during the planned break.
23. A method according to any preceding claim wherein the schedule includes programmes which are not directly accessible by the scheduling device.
24. A method according to any preceding claim wherein multiple user preferences are stored.
25. A method according to Claim 24 including providing multiple user schedules.
26. A method according to any preceding claim wherein two or more user preferences are merged to create at least one group preference.
27. A method according to any of Claims 24 to 26 including providing at least one user group schedule.

28. A method according to any preceding claim comprising at least a step of ordering programmes according to time of broadcast or availability and a step of ordering the programmes according to closeness of match to user criteria.
- 5 29. Apparatus configured to perform a method according to any preceding claim.
30. Apparatus according to Claim 22 comprising:
means for receiving a schedule of broadcast programmes;
means for storing a list of stored programmes;
10 means for storing user preference information;
means for compiling a user schedule based on on the received schedule of broadcast programmes, the stored list of stored programmes and the user preference information;
means for outputting the user schedule.
- 15 31. Apparatus according to Claim 30, further comprising means for playing out media corresponding to the user schedule.
32. Apparatus according to Claim 30 or 31, further comprising means for
20 controlling media storage apparatus.
33. Apparatus according to Claim 30 or 31, further comprising media storage apparatus.
- 25 34 Apparatus according to any of Claims 30 to 33, further comprising means for receiving a programme from a remote video-on-demand server.
35. Apparatus according to any of Claims 30 or 34, further comprising means for receiving programmes via a network, preferably the internet.
- 30 36. Apparatus according to Claim 35 arranged to receive a programme over the network at a download rate, to store the programme and to play out the programme at a playback rate for real-time playback.

-17-
~~28~~

37. Apparatus according to Claim 36, wherein the download rate is lower than the playback rate.

5 38. Apparatus according to Claim 37, including means for setting a download start time in advance of a desired playback time.

39. A computer program or computer program product comprising instructions for performing a method according to any of Claims 1 to 28.



INVESTOR IN PEOPLE

Application No: GB 0211159.9
Claims searched: 1 and 10

Examiner: Natasha Jenkins
Date of search: 5 November 2002

Patents Act 1977 Search Report under Section 17

Databases searched:

UK Patent Office collections, including GB, EP, WO & US patent specifications, in:
UK CI (Ed.T): H4F FBBG FBB
Int CI (Ed.7): H04N 5/455 7/088
Other: Online: EPODOC, PAJ, WPI

Documents considered to be relevant:

Category	Identity of document and relevant passage	Relevant to claims
A	GB 2325537 A MICROSOFT CORP	
X	WO 00/40021 A1 KONINKLIJKE PHILIPS ELECTRONICS. See page 1, line 22 - page 2, line 10, page 2 lines 24 - 32	1, 10, 11 and 14, at least
X	WO 00/16548 A1 UNITED VIDEO PROPERTIES INC. See page 2 lines 6 - 17 & lines 22 - 28, page 3, line 25 - page 4, line 10	1, 10, 11 and 14, at least
X	US 6005597 A BARRETT ET AL. See all, especially column 14, lines 13-23.	1, 10, 11 and 14, at least

X	Document indicating lack of novelty or inventive step	A	Document indicating technological background and/or state of the art.
Y	Document indicating lack of inventive step if combined with one or more other documents of same category.	P	Document published on or after the declared priority date but before the filing date of this invention.
&	Member of the same patent family	E	Patent document published on or after, but with priority date earlier than, the filing date of this application.